

Dynamic Ideal Free Distribution: Effects of Optimal Patch Choice on Predator-Prey Dynamics



Vlastimil Krivan

The American Naturalist, Vol. 149, No. 1 (Jan., 1997), 164-178.

Stable URL:

<http://links.jstor.org/sici?sici=0003-0147%28199701%29149%3A1%3C164%3ADIFDEO%3E2.0.CO%3B2-X>

The American Naturalist is currently published by The University of Chicago Press.

Your use of the JSTOR archive indicates your acceptance of JSTOR's Terms and Conditions of Use, available at <http://www.jstor.org/about/terms.html>. JSTOR's Terms and Conditions of Use provides, in part, that unless you have obtained prior permission, you may not download an entire issue of a journal or multiple copies of articles, and you may use content in the JSTOR archive only for your personal, non-commercial use.

Please contact the publisher regarding any further use of this work. Publisher contact information may be obtained at <http://www.jstor.org/journals/ucpress.html>.

Each copy of any part of a JSTOR transmission must contain the same copyright notice that appears on the screen or printed page of such transmission.

JSTOR is an independent not-for-profit organization dedicated to creating and preserving a digital archive of scholarly journals. For more information regarding JSTOR, please contact support@jstor.org.

DYNAMIC IDEAL FREE DISTRIBUTION: EFFECTS OF OPTIMAL PATCH CHOICE ON PREDATOR-PREY DYNAMICS

VLASTIMIL KŘIVAN*

Biomathematics, Institute of Entomology, Academy of Sciences of the Czech Republic,
Branišovská 31, 370 05 České Budějovice, Czech Republic

Submitted August 8, 1995; Revised March 25, 1996; Accepted March 29, 1996

Abstract.—This study examines the influence of individual behavior on predator-prey dynamics in a two-patch environment. I assume that individuals behave to maximize their fitness measured by the instantaneous per capita growth rate. The population dynamics in each patch are described by the Lotka-Volterra continuous model. Two cases are studied in detail. The first case assumes only predators are free to move between patches, whereas the second assumes that both predators and prey move freely between patches. The study shows that the optimal behavior of animals leads to persistence of predator-prey systems and reduction of oscillations in population densities.

In this article, I develop a dynamic framework for modeling the spatial distribution of predator and prey populations, assuming animals behave optimally (i.e., they maximize their fitness). I follow the idea behind the ideal free distribution (Fretwell and Lucas 1970; Kacelnik et al. 1992), which describes the equilibrium distribution of a population of predators among several habitat patches. The Fretwell and Lucas model assumes that predators are free to settle in any patch, travel time between patches is zero, predators are omniscient, and resource densities in patches remain constant through time (Kacelnik et al. 1992). If each predator settles in the patch where its rate of resource acquisition is maximized, the model predicts that at equilibrium, predators in all patches will experience the same intake rate. The original Fretwell and Lucas model was modified in several directions to include factors such as interference (Sutherland 1983), differences in competitive ability (Sutherland and Parker 1985; Parker and Sutherland 1986), perceptual constraints (Abrahams 1986), learning (Bernstein et al. 1988), and resource dynamics (Lessells 1995). However, the original Fretwell and Lucas model and these generalizations do not consider predator-prey dynamics that in turn will influence the distribution of predators and prey among patches. Moreover, the optimality criterion based on maximization of energy intake should also be replaced by a more general criterion that includes the consequences of variation in predator mortality rates among all patches. In natural communities, the richer habitat is often also the more dangerous one, owing to a higher predation

* E-mail: krivan@entu.cas.cz.

rate (Werner et al. 1983). Thus, there is a trade-off between energy intake and mortality rate.

Hassell and May (1973) considered the population dynamics of a host-parasitoid system described by the discrete-time Nicholson-Bailey model. If parasitoids search at random, their model has one unstable equilibrium. Any deviation from this equilibrium leads to oscillations with increasing amplitude, preventing the indefinite persistence (Hofbauer and Sigmund 1984) of both parasitoids and hosts. Strong aggregation of parasitoids to patches of higher prey density may stabilize the otherwise unstable Nicholson-Bailey model (Hassell and May 1973). For Lotka-Volterra continuous models, aggregation of parasitoids (or predators) may have either a stabilizing or destabilizing effect on population dynamics, depending on the strength of aggregation (Murdoch and Stewart-Oaten 1989). In their article, Murdoch and Stewart-Oaten (1989) argued on empirical grounds that in nature, destabilization would prevail. Godfray and Pacala (1992) showed that the effect of aggregation on stability depends on the meaning of the term *aggregation*. Hassell and May (1973) defined aggregation in terms of parasitoid host-searching behavior, whereas Murdoch and Stewart-Oaten (1989) apply a statistical meaning. The influence of individual behavior of animals on population dynamics was further elaborated by van Baalen and Sabelis (1993), who used game theory to define evolutionarily stable strategies of predators and prey. Based on the discrete-time Nicholson-Bailey model, van Baalen and Sabelis argued that evolutionary stability leads to the ideal free distribution but that the conditions for evolutionary stability may exclude the possibility of high parasitoid aggregation. Thus, evolutionary stability may counteract the stabilizing effect of aggregation.

This article considers population dynamics described by Lotka-Volterra differential equations with controls that model the individual decisions of predators and prey. Assuming that individuals behave optimally (i.e., they maximize their fitness, measured through the instantaneous net reproductive rate), I derive a model that links individual behavior and population dynamics. Two cases are analyzed in detail. The first case assumes no prey migration among patches, but predators are free to move. The second case assumes that both predators and prey are free to move. This article explores the effect of individual decisions on persistence and stability of predator-prey (or host-parasitoid) systems. Therefore, I do not include in the models any other mechanism (e.g., density dependence or passive diffusion of prey among patches; Holt 1983, 1984, 1985) that could alone lead to a stable equilibrium. Instead, I start with Lotka-Volterra models that do not have an asymptotically stable equilibrium and study the consequences of optimal individual behavior for population dynamics. My main questions are, What is the effect of optimal individual behavior on population dynamics? Does optimal individual behavior lead to persistence, stability, or instability of population dynamics?

POPULATION DYNAMICS

In this section, I derive a general dynamic model for a two-patch predator-prey system. I first consider mobile predators and immobile prey. The prey abundance

in patch i ($= 1, 2$) at time t is denoted by $x_i(t)$, and the total predator abundance is denoted by $y(t)$. The encounter rate of a predator with prey in patch i is $\lambda_i x_i$, and the expected net energy obtained from one item of food is e_i . Neglecting expected handling times and assuming that prey grow exponentially without predators, I get the Lotka-Volterra system

$$\begin{aligned}x'_1 &= a_1 x_1 - \lambda_1 x_1 u_1 y, \\x'_2 &= a_2 x_2 - \lambda_2 x_2 u_2 y,\end{aligned}\tag{1}$$

and

$$y' = (e_1 \lambda_1 x_1 - m_1) u_1 y + (e_2 \lambda_2 x_2 - m_2) u_2 y.$$

Here a_i and m_i are instantaneous per capita growth and mortality rates in patch i , respectively, and u_i denotes the probability that a predator will be in patch i . I assume that predators move infinitely fast between patches so $u_1 + u_2 = 1$ (i.e., each predator is in either patch 1 or patch 2). Thus, $u_1 = 1$ means that all predators aggregate in patch 1. Strategies $u_1 = 1, u_2 = 0$ and $u_1 = 0, u_2 = 1$ are pure strategies, whereas all other strategies are mixed strategies. Mixed strategies lead to the partial preferences of predators for each habitat. However, the controls u_i are not assumed to be constant; they may change in time.

I next consider the case in which both predators and prey are mobile. The total abundance of prey is x , and the probability that prey stay in patch i is v_i . Thus,

$$\begin{aligned}x &= x_1 + x_2, \\x_1 &= v_1 x, \\x_2 &= v_2 x,\end{aligned}$$

and

$$\begin{aligned}x' &= (a_1 - \lambda_1 u_1 y) v_1 x + (a_2 - \lambda_2 u_2 y) v_2 x, \\y' &= (e_1 \lambda_1 v_1 x - m_1) u_1 y + (e_2 \lambda_2 v_2 x - m_2) u_2 y.\end{aligned}\tag{2}$$

Again I assume that both predators and prey move between patches infinitely fast and $u_1 + u_2 = v_1 + v_2 = 1$ (i.e., each animal is either in patch 1 or patch 2).

Without loss of generality, in the rest of the article I assume that the growth rate of prey in patch 1 is greater than or equal to the growth rate in patch 2 (i.e., $a_1 \geq a_2$).

ONLY PREDATORS ARE FREE TO MOVE

Classical optimal foraging theory (Stephens and Krebs 1986) assumes that predators maximize their energy intake. However, when predators' mortality rates are not the same across patches, optimality becomes a complex problem: patches with higher energy acquisition rates may be riskier. This results in a trade-off dilemma for predators: stay in a better but riskier patch, or move? To solve this problem, I define an optimality criterion based on the maximization of predator

fitness. I assume that fitness is measured through the instantaneous net reproductive rate (Sibly 1991). This maximizes the per-predator growth rate over all possible controls u_1, u_2 :

$$\max_{(u_1, u_2)} (e_1 \lambda_1 x_1 - m_1) u_1 + (e_2 \lambda_2 x_2 - m_2) u_2. \quad (3)$$

Note that this criterion differs from the maximization of the instantaneous rate of energy acquisition if mortality rates in the two patches are different. If $m_1 = m_2 = m$, then both criteria lead to the same optimality principle.

The optimal strategy is the set of controls (u_1, u_2) that maximize expression (3) for given abundances of prey (x_1, x_2) . Since the optimal strategy depends on x_1, x_2 , it is not constant over time. I split the $x_1 > 0, x_2 > 0, y > 0$ space into three parts according to values of the optimal strategy. Because expression (3) is a linear function of u_1 and u_2 , it follows that predators aggregate in patch 1 ($u_1 = 1, u_2 = 0$) if $e_1 \lambda_1 x_1 - m_1 > e_2 \lambda_2 x_2 - m_2$ (denoted by G^1 in fig. 1), predators aggregate in patch 2 ($u_1 = 0, u_2 = 1$) if $e_1 \lambda_1 x_1 - m_1 < e_2 \lambda_2 x_2 - m_2$ (denoted by G^2 in fig. 1), and the predators' fitness is the same in both patches (u_1, u_2 are not uniquely determined) if $e_1 \lambda_1 x_1 - m_1 = e_2 \lambda_2 x_2 - m_2$. This is the classic ideal free distribution in which no predator can increase its fitness by moving to the other patch, and it is denoted by G^0 in figure 1.

Note that if $m_1 \geq m_2$, then only the part of the plane G^0 for which

$$x_1 > \frac{m_1 - m_2}{e_1 \lambda_1} \quad (4)$$

belongs to the positive octant (fig. 1A), whereas if $m_1 < m_2$, I obtain

$$x_2 > \frac{m_2 - m_1}{e_2 \lambda_2}$$

(see fig. 1B).

Global qualitative analysis for system (1) driven by the optimal strategy is possible using a Lyapunov function. Trajectories of equations (1) driven by the optimal strategy (which are uniquely defined; see app. A) do converge to a subset of G^0 that I denote by A in figure 1. Such a set is called a global attractor, because in the limit, all trajectories of equations (1) governed by the optimal strategy will move in A . The optimal strategy (i.e., the partial preferences governing the dynamics of eqq. [1] on the attractor) is given by

$$u_1^*(x_1, y) = \frac{a_1 e_1 \lambda_1 x_1 + (e_1 \lambda_1 x_1 - m_1 + m_2)(\lambda_2 y - a_2)}{[e_1 \lambda_1^2 x_1 + \lambda_2 (e_1 \lambda_1 x_1 - m_1 + m_2)] y}. \quad (5)$$

Using this control, I compute the ideal free distribution (i.e., the ratio between the abundance of predators in the two patches):

$$\frac{u_1^*}{u_2^*} = \frac{e_1 \lambda_1 x_1 (\lambda_2 y - a_2 + a_1) + (\lambda_2 y - a_2)(m_2 - m_1)}{e_1 \lambda_1 x_1 (\lambda_1 y + a_2 - a_1) + a_2 (m_2 - m_1)}. \quad (6)$$

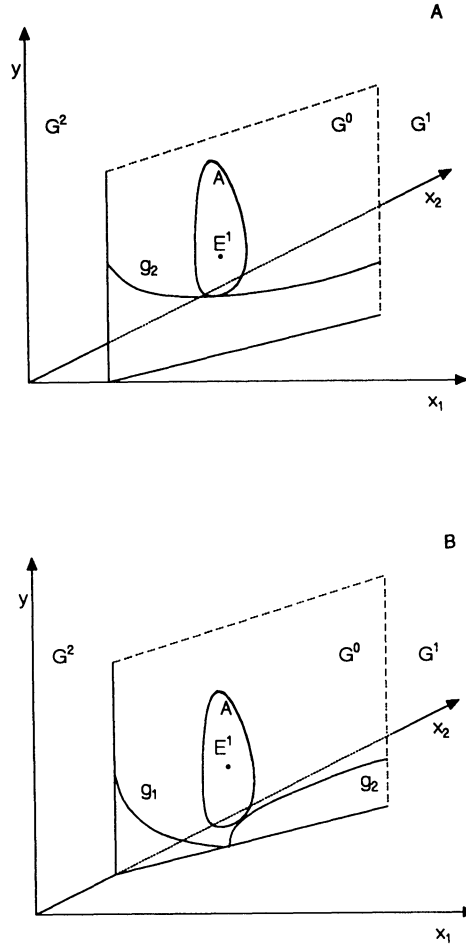

FIG. 1.—Position of the global attractor A of equations (1) driven by the optimal strategy maximizing the predator growth rate. All trajectories of equations (1) driven by the optimal strategy converge to A . The attractor A is a subset of the plane G^0 where partial preferences do appear. The dynamics on the attractor are described by equations (7). In A , the predator mortality rate in the first patch is higher than in the second patch (i.e., $m_1 > m_2$), whereas in B , it is lower ($m_1 < m_2$).

Substituting this ideal free distribution into equations (1) gives the following differential equations describing the dynamics on the attractor:

$$\begin{aligned}
 x_1' &= \frac{x_1(m_1 - m_2 - e_1\lambda_1x_1)(\lambda_1\lambda_2y - a_1\lambda_2 - a_2\lambda_1)}{e_1\lambda_1x_1(\lambda_1 + \lambda_2) + \lambda_2(m_2 - m_1)}, \\
 x_2' &= \frac{x_2(m_2 - m_1 - e_2\lambda_2x_2)(\lambda_1\lambda_2y - a_1\lambda_2 - a_2\lambda_1)}{e_2\lambda_2x_2(\lambda_1 + \lambda_2) + \lambda_1(m_1 - m_2)}, \\
 y' &= (e_1\lambda_1x_1 - m_1)y.
 \end{aligned} \tag{7}$$

But the second equation in equations (7) is redundant because in G^0 (and thus in A) it holds automatically, because

$$x_2 = \frac{e_1 \lambda_1 x_1 - m_1 + m_2}{e_2 \lambda_2}.$$

The trajectories of equations (7) are closed curves in G^0 centered on the equilibrium point

$$E^1 = \left(\frac{m_1}{e_1 \lambda_1}, \frac{m_2}{e_2 \lambda_2}, \frac{a_2 \lambda_1 + a_1 \lambda_2}{\lambda_1 \lambda_2} \right),$$

which is neutrally stable. The attractor A is given by the subset of G^0 bounded by the largest cycle of equations (7) above the graph of

$$g(x_1) = \max\{g_1(x_1), g_2(x_1)\},$$

where

$$g_1(x_1) = \frac{e_1 \lambda_1 x_1 (a_2 - a_1) + a_2 (m_2 - m_1)}{\lambda_2 (e_1 \lambda_1 x_1 + m_2 - m_1)},$$

and

$$g_2(x_1) = \frac{a_1 - a_2}{\lambda_1} + \frac{a_2 (m_1 - m_2)}{\lambda_1^2 e_1 x_1}.$$

The graph of g splits G^0 into two (fig. 1A) or three (fig. 1B) parts. The transient behavior of trajectories of equations (1) driven by the optimal strategy (i.e., the behavior of trajectories of eqq. [1] before they reach the attractor A) can be described in the following way. If a trajectory of equations (1) driven by the optimal strategy reaches G^0 at a point below the graph of g (i.e., below the graph of g_2 in fig. 1A and below the graphs of g_1 and g_2 in fig. 1B), it will cross G^0 transversally. At points below the graph of g_1 , trajectories of equations (1) cross G^0 in the direction from G^1 toward G^2 and at points below the graph of g_2 in the opposite direction. If a trajectory of equations (1) driven by the optimal strategy reaches a point in G^0 above the graph of g , then it will continue to move along G^0 following a cycle given by equations (7). If this cycle is inside the attractor A , then the trajectory will follow this cycle forever (see fig. 2). If the cycle is not entirely inside the attractor, then the trajectory will leave G^0 when it crosses the graph of g . However, in the limit all trajectories will reach the attractor.

Because all trajectories of equations (1) governed by the optimal strategy converge to the attractor A (which is a subset of G^0 where partial preferences do occur), the predator population will necessarily spread over both patches, and the originally uncoupled dynamics of prey populations in system (1) will become coupled in system (7). Thus, optimal behavior of predators affects the nature of interactions among prey populations.

I now examine the two cases with respect to predator mortality rates. First, consider the case when the first patch is riskier—that is, when $m_1 > m_2$ (see fig. 1A). Then $g_1(x_1) < 0$ in G^0 because of inequality (4) and the fact that $a_1 \geq a_2$,

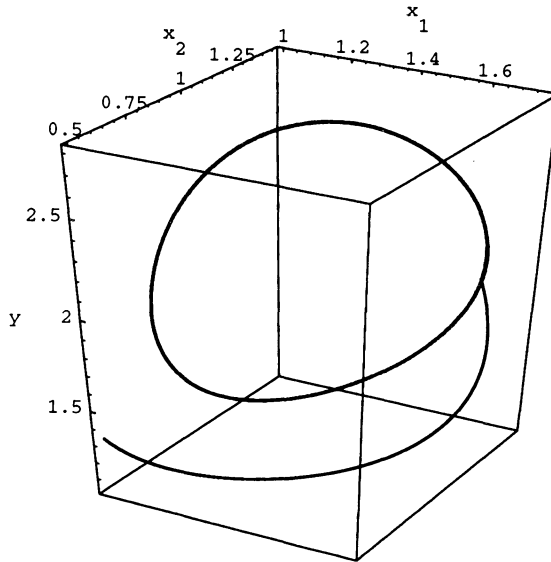

FIG. 2.—A solution of equations (1) plotted in space. In this figure only predators follow the optimal patch choice. The trajectory converges to a cycle given by equations (7) inside the attractor A . Parameters are as follows: $a_1 = 1.5$, $a_2 = 0.5$, $e_1 = 1.5$, $e_2 = 1$, $\lambda_1 = \lambda_2 = 1$, $m_1 = 2$, and $m_2 = 1$.

and the attractor is constrained from below only by the graph of g_2 . At the limit prey abundance in patch 1 will never fall below $(m_1 - m_2)/(e_1\lambda_1)$ (see inequality [4]), and the predator abundance will never fall below $(a_1 - a_2)/\lambda_1$ (which is the asymptote of g_2).

If $m_1 < m_2$, the attractor is constrained from below by the graph of either g_1 or g_2 (see fig. 1B). At the limit, the prey abundance in patch 2 will always be larger than $(m_1 - m_2)/(e_2\lambda_2)$.

If predator mortality rates in both patches are the same, $m_1 = m_2 = m$ (Colombo and Krivan 1993), then

$$g_2(x_1) = y^* = \frac{a_1 - a_2}{\lambda_1}$$

is a straight line and g_1 is always negative. Thus, at the limit the predator density cannot fall below y^* . The dynamics on the attractor A are described by the Lotka-Volterra system

$$\begin{aligned} x_1' &= \frac{a_1\lambda_2 + a_2\lambda_1}{\lambda_1 + \lambda_2} x_1 - \frac{\lambda_1\lambda_2}{\lambda_1 + \lambda_2} x_1 y, \\ x_2' &= \frac{a_1\lambda_2 + a_2\lambda_1}{\lambda_1 + \lambda_2} x_2 - \frac{\lambda_1\lambda_2}{\lambda_1 + \lambda_2} x_2 y, \end{aligned} \quad (8)$$

and

$$y' = (e_1\lambda_1 x_1 - m)y.$$

The attractor A is given by a subset of G^0 bounded by the largest Lotka-Volterra cycle of equations (8) above the line y^* . The amplitude of this largest cycle may be measured by the distance of the equilibrium of equations (8) from y^* . This distance is given by

$$\frac{a_2(\lambda_1 + \lambda_2)}{\lambda_1 \lambda_2}. \tag{9}$$

Thus, if a_2 is small, the limit cycle has a small amplitude.

The ideal free distribution is

$$\frac{u_1^*}{u_2^*} = \frac{a_1 - a_2 + \lambda_2 y}{a_2 - a_1 + \lambda_1 y}. \tag{10}$$

If prey populations in both patches are identical (i.e., $a_1 = a_2, \lambda_1 = \lambda_2$), then the above fraction will be one; that is, half of the predator population will be in patch 1 and the other half in patch 2. The control ratio u_1^*/u_2^* decreases with increasing y if $a_1 > a_2$.

When predators move randomly between patches u_1, u_2 are held fixed over time. Then the dynamics of equations (1) are very simple. Assuming that $a_1 \lambda_2 u_2 > a_2 \lambda_1 u_1$, then there is one globally stable equilibrium

$$\left(\frac{m_1 u_1 + m_2 u_2}{e_1 \lambda_1 u_1}, 0, \frac{a_1}{\lambda_1 u_1} \right)$$

(see app. B). This equilibrium is not asymptotically stable. The prey population in patch 2 dies out, and the resulting dynamics are described by Lotka-Volterra cycles in the (x_1, y) plane. Similarly, if $a_1 \lambda_2 u_2 < a_2 \lambda_1 u_1$, then the prey population in patch 1 dies out. Thus, the system with predators moving randomly between patches is not persistent because prey in one patch always die out.

BOTH PREY AND PREDATORS ARE FREE TO MOVE

The model assumes that when both predators and prey are freely mobile, they move with infinite speed (so at each instant every prey and predator is either in patch 1 or patch 2). The population dynamics are described by the Lotka-Volterra equations (2). Because both predators and prey are free to move, their fitness expressed as instantaneous growth rate should be simultaneously maximized:

$$\max_{(v_1, v_2)} (a_1 - \lambda_1 u_1 y) v_1 + (a_2 - \lambda_2 u_2 y) v_2 \tag{11}$$

and

$$\max_{(u_1, u_2)} (e_1 \lambda_1 v_1 x - m_1) u_1 + (e_2 \lambda_2 v_2 x - m_2) u_2. \tag{12}$$

To determine which control $(v^*, u^*) = (v_1^*, v_2^*, u_1^*, u_2^*)$ is the optimal one, I use

game theory. A pair (v^*, u^*) is considered optimal if

$$(a_1 - \lambda_1 u_1^* y) v_1^* + (a_2 - \lambda_2 u_2^* y) v_2^* \geq (a_1 - \lambda_1 u_1^* y) v_1 + (a_2 - \lambda_2 u_2^* y) v_2,$$

and

$$(e_1 \lambda_1 v_1^* x - m_1) u_1^* + (e_2 \lambda_2 v_2^* x - m_2) u_2^* \geq (e_1 \lambda_1 v_1^* x - m_1) u_1 + (e_2 \lambda_2 v_2^* x - m_2) u_2$$

for all (u_1, u_2) and (v_1, v_2) between zero and one. The optimal strategy (u^*, v^*) is a Nash equilibrium, because at a Nash equilibrium no individual can unilaterally increase its fitness by changing its strategy. An invasion-proof Nash equilibrium is an evolutionarily stable strategy (Hofbauer and Sigmund 1984). The Nash equilibrium (v_1^*, u_1^*) , assuming $a_1 \geq a_2$ and $m_1 \geq m_2$, is

- (a) $\left[\frac{m_1 - m_2 + e_2 \lambda_2 x}{(e_1 \lambda_1 + e_2 \lambda_2) x}, \frac{a_1 - a_2 + \lambda_2 y}{(\lambda_1 + \lambda_2) y} \right]$ if $x > \frac{m_1 - m_2}{e_1 \lambda_1}$, $y > \frac{a_1 - a_2}{\lambda_1}$,
- (b) (1, 1) if $x > \frac{m_1 - m_2}{e_1 \lambda_1}$, $y < \frac{a_1 - a_2}{\lambda_1}$,
- (c) (1, 0) if $x < \frac{m_1 - m_2}{e_1 \lambda_1}$

(see app. C). If prey abundance is low (case [c]), all prey will be in patch 1 while predators will stay in patch 2. Because the mortality rate for predators in patch 1 is higher than in patch 2 and prey abundance is low, patch 2 is a refuge for predators. If predator abundance is low and prey abundance is high (case [b]), both predators and prey will aggregate in patch 1.

If $a_1 \geq a_2$ and $m_1 < m_2$, the Nash equilibrium is

- (a') $\left[\frac{m_1 - m_2 + e_2 \lambda_2 x}{(e_1 \lambda_1 + e_2 \lambda_2) x}, \frac{a_1 - a_2 + \lambda_2 y}{(\lambda_1 + \lambda_2) y} \right]$ if $x > \frac{m_2 - m_1}{e_2 \lambda_2}$, $y > \frac{a_1 - a_2}{\lambda_1}$,
- (b') (1, 1) if $y < \frac{a_1 - a_2}{\lambda_1}$,
- (c') (0, 1) if $x < \frac{m_2 - m_1}{e_2 \lambda_2}$, $y > \frac{a_1 - a_2}{\lambda_1}$.

If predator abundance is low (case [b']), both predators and prey will aggregate in patch 1. This is because the prey growth rate in patch 1 is higher than that in patch 2, and if predator abundance is low (i.e., predation rate is low), then prey should stay in patch 1. Predators will also aggregate in this patch, because the predator mortality rate is lower there. If prey abundance is low and predator abundance is high (case [c']), then patch 1 is no longer better for prey, and they move to patch 2. However, patch 2's predator mortality rate is high, so predators take refuge in patch 1.

Consider the case when the first patch is more dangerous (i.e., $m_1 > m_2$). Using a Lyapunov function, it can be shown that trajectories of equations (2) driven by

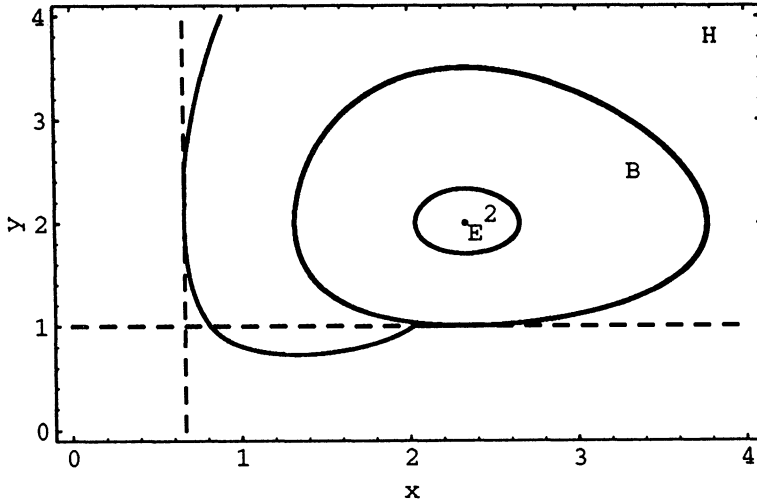

FIG. 3.—Two solutions of equations (2) plotted in space. In this figure, both predators and prey follow the optimal patch choice. One solution converges from outside to the attractor *B*, which is bounded by the largest cycle of equations (14) inside the set *H*, whereas the other solution lies inside the attractor *B*. Parameters are the same as those given in figure 2.

the optimal strategy do converge to a global attractor (denoted by *B* in fig. 3), which is a subset of

$$H = \left\{ (x, y) \mid x \geq \frac{m_1 - m_2}{e_1 \lambda_1}, y \geq \frac{a_1 - a_2}{\lambda_1} \right\}.$$

The ideal free distribution of predators is given by equation (10) and of prey by

$$\frac{v_1^*}{v_2^*} = \frac{m_1 - m_2 + e_2 \lambda_2 x}{m_2 - m_1 + e_1 \lambda_1 x}. \tag{13}$$

Substituting this ideal free distribution into equations (2) gives the following differential equations describing the dynamics on the attractor:

$$x' = x \left(\frac{a_2 \lambda_1 + a_1 \lambda_2}{\lambda_1 + \lambda_2} - \frac{\lambda_1 \lambda_2}{\lambda_1 + \lambda_2} y \right),$$

and (14)

$$y' = y \left(-\frac{e_1 \lambda_1 m_2 + e_2 \lambda_2 m_1}{e_1 \lambda_1 + e_2 \lambda_2} + \frac{e_1 e_2 \lambda_1 \lambda_2}{e_1 \lambda_1 + e_2 \lambda_2} x \right).$$

The trajectories of equations (14) are the Lotka-Volterra cycles centered on the equilibrium point

$$E^2 = \left(\frac{e_1 \lambda_1 m_2 + e_2 \lambda_2 m_1}{e_1 e_2 \lambda_1 \lambda_2}, \frac{a_1 \lambda_2 + a_2 \lambda_1}{\lambda_1 \lambda_2} \right),$$

which is neutrally stable. The attractor B is given by the subset of H bounded by the largest cycle of equations (14) inside H .

There are two possibilities for trajectories. Either the initial condition is inside the attractor and the corresponding trajectory follows a Lotka-Volterra cycle of equations (14) (see fig. 3), or the initial condition is outside the attractor, and the corresponding trajectory converges to the largest cycle of equations (14) inside the set H . Thus, this largest limit cycle is asymptotically stable from outside and neutrally stable from inside. The amplitude of the largest limit cycle depends on the distance of the equilibrium E^2 to the boundary of H , which is

$$\min \left\{ \frac{m_2(e_1\lambda_1 + e_2\lambda_2)}{e_1e_2\lambda_1\lambda_2}, \frac{a_2(\lambda_1 + \lambda_2)}{\lambda_1\lambda_2} \right\}.$$

Therefore, the amplitude of the limiting cycle is small if either a_2 or m_2 is small. The analysis for the case when $m_1 < m_2$ follows the same lines and leads to similar results.

The random movement of predators and prey corresponds to the case of fixed values of controls u_1, u_2, v_1, v_2 . Then equations (2) is the classical Lotka-Volterra system with a neutrally stable equilibrium surrounded by closed curves.

DISCUSSION

In this article I have developed a theory of ideal free distributions that allows for predator-prey population dynamics. If animals are perfect optimizers, the resulting dynamics have a neutrally stable equilibrium surrounded by closed trajectories. A global attractor bounded by a limit cycle appears, owing to the optimal individual behavior of animals. The ratio of predators in different patches is not fixed (because the system is not in equilibrium) but changes over time. The amplitude of the limit cycle depends on the model's parameters. For example, if the growth rate of the prey population in the patch with lower growth rate tends to zero, the amplitude of the limit cycle tends to zero too. It is interesting to compare dynamics when animals behave optimally versus when they move randomly. When predators move freely and randomly but prey do not, the system is not persistent because the prey population in the patch with the smaller value of $a_i\lambda_i u_i$ is always depleted by predators. This result does not depend on predator mortality rates. However, when predators behave optimally, the same system is persistent because when prey abundance in one patch declines, predators move away and the prey population may recover. After some time, the first patch becomes more attractive to predators than the second because of the prey population's exponential growth rate. When both prey and predators move freely and randomly, the system is persistent, but the limit cycle that appears when predators and prey behave optimally does not exist.

Qualitatively, both situations lead to the same conclusions. The assumption of optimal behavior with Lotka-Volterra dynamics leads to persistence of the system in which only predators are mobile, reduced amplitude of fluctuations in population densities, and the predator-mediated coexistence of prey populations. If sta-

bility is measured by the amplitude of the system's largest fluctuations, this article shows that optimal individual behavior has a partially stabilizing effect on Lotka-Volterra dynamics.

Because of the Lotka-Volterra dynamics, the system does not converge to an ecological equilibrium; thus, the basic assumption behind the Fretwell and Lucas model is not satisfied. Despite this, the model still predicts that after a transient period during which animals may aggregate in one patch, the system will reach a dynamic ideal free distribution in which no individual can increase its fitness by moving to the other patch. However, ecological equilibrium is not reached, and population densities do fluctuate around this equilibrium. So the ideal free distribution in the Fretwell and Lucas sense is reached although the system is not in equilibrium. The distribution of animals is given by equation (6) if only predators move freely and by equations (10) and (13) if both predators and prey move freely. These distributions depend not only on the prey abundance but also on the predator abundance. If predator mortality rates are the same in both patches, or if both predators and prey move freely, the ratio between the prey abundance in the first and second patch decreases when the predator abundance increases.

Substituting the more realistic Holling Type II response function, which does not omit handling times, for the Holling Type I functional response, which leads to Lotka-Volterra systems (eqq. [1], [2]) into the model described by equations (1) gives

$$\begin{aligned}x_1' &= a_1 x_1 - \frac{\lambda_1 x_1 u_1}{1 + h_1 \lambda_1 x_1} y, \\x_2' &= a_2 x_2 - \frac{\lambda_2 x_2 u_2}{1 + h_2 \lambda_2 x_2} y,\end{aligned}\tag{15}$$

and

$$y' = \left(\frac{e_1 \lambda_1 x_1}{1 + h_1 \lambda_1 x_1} - m_1 \right) u_1 y + \left(\frac{e_2 \lambda_2 x_2}{1 + h_2 \lambda_2 x_2} - m_2 \right) u_2 y.$$

For predators moving at random (i.e., u_1, u_2 fixed), model (15) has one positive equilibrium, which is unstable. The trajectories spiral away from this equilibrium with increasing amplitude, and, consequently, the dynamics are not persistent. This model resembles the discrete-time Nicholson-Bailey model, which is also not persistent. Mathematical analysis of system (15) with the optimal strategy given by maximization of the predators' growth rate is more complex, and global behavior of trajectories of equations (15) with the optimal strategy cannot be described analytically. However, numerical simulations show that optimal behavior of predators again may lead to persistence. This is in an agreement with the work of Holt (1983, 1984, 1985, 1987), who studied the effect of optimal habitat selection on the stability of predator-prey dynamics. However, Holt's work assumed that when an ideal free distribution is reached, the system is in equilibrium. This may be the case when each prey population grows logistically (Holt 1984,

1987). Whether the system reaches a stable equilibrium depends on the underlying dynamics. My analysis does not assume that when an ideal free distribution is reached, the population should also reach an equilibrium. Moreover, because my model does not assume any other stabilizing mechanism (like density dependence or passive diffusion between patches; Holt 1983, 1985), I proved that optimal patch choice alone leads to persistence of predator-prey dynamics. Numerical simulations show that the system may converge to a stable equilibrium when logistic growth is included.

ACKNOWLEDGMENTS

This research was funded by the Grant Agency of the Academy of Sciences of the Czech Republic (grant 107101). I thank D. Boukal and C. Bernstein for stimulating discussion, I. Dostálková for her computer assistance, and two anonymous referees for their useful suggestions.

APPENDIX A

UNIQUENESS OF TRAJECTORIES OF EQUATIONS (1) AND (2)

Including optimality criterion (3) and equations (11) and (12), respectively, into Lotka-Volterra models (1) and (2) yields differential equations in which the right sides are multi-valued. This may raise some questions concerning how well posed the model is. However, the results given in Colombo and Křivan (1993) show that the Lotka-Volterra-type models used in this article have uniquely defined solutions. I omit these mathematical details and most other formal proofs that are published elsewhere.

APPENDIX B

GLOBAL ANALYSIS OF SYSTEM (1) WHEN PREDATORS MOVE AT RANDOM

Assume that u_1, u_2 are fixed. Let

$$V(x_1, x_2, y) = \frac{1}{\lambda_1 u_1} \left[x_1 e_1 \lambda_1 u_1 - (m_1 u_1 + m_2 u_2) - (m_1 u_1 + m_2 u_2) \ln \left(\frac{x_1 e_1 \lambda_1 u_1}{m_1 u_1 + m_2 u_2} \right) \right] \\ + e_2 x_2 + \left[y - \frac{a_1}{\lambda_1 u_1} - \frac{a_1}{\lambda_1 u_1} \ln \left(\frac{y \lambda_1 u_1}{a_1} \right) \right].$$

Then along the trajectories of equations (1), I get

$$\frac{d}{dt} V[x(t)] = \left(\frac{a_2}{\lambda_2 u_2} - \frac{a_1}{\lambda_1 u_1} \right) e_2 \lambda_2 u_2 x_2,$$

which is negative for

$$\left(\frac{a_2}{\lambda_2 u_2} - \frac{a_1}{\lambda_1 u_1} \right) < 0. \quad (16)$$

Thus, V is a Lyapunov function for system (1), and under assumption (16) the second population of prey dies out. In the (x_1, y) plane, the dynamics follow Lotka-Volterra cycles.

APPENDIX C

COMPUTATION OF NASH EQUILIBRIA

Let

$$f_1(v_1, u_1) = (a_1 - \lambda_1 u_1 y) v_1 + [a_2 - \lambda_2(1 - u_1)y](1 - v_1)$$

and

$$f_2(v_1, u_1) = (e_1 \lambda_1 v_1 x - m_1) u_1 + [e_2 \lambda_2(1 - v_1)x - m_2](1 - u_1).$$

The Nash equilibrium is the set $N(x, y)$ of those controls (v^*, u^*) that satisfy

$$f_1(v_1^*, u_1^*) \geq f_1(v_1, u_1^*), \quad f_2(v_1^*, u_1^*) \geq f_2(v_1^*, u_1)$$

for all $v_1 \in [0, 1], u_1 \in [0, 1]$. Solving

$$\frac{\partial f_1}{\partial v_1} = 0, \quad \frac{\partial f_2}{\partial u_1} = 0$$

gives

$$v_1^* = \frac{m_1 - m_2 + e_2 \lambda_2 x}{(e_1 \lambda_1 + e_2 \lambda_2)x}, \quad u_1^* = \frac{a_1 - a_2 + \lambda_2 y}{(\lambda_1 + \lambda_2)y}.$$

For a fixed $u_1 \in [0, 1]$, f_1 is maximized at the points of the set

$$M_{f_1}(u_1) = \begin{cases} (1, u_1) & \text{if } u_1 \in [0, u_1^*), \\ \{(v_1, u_1^*) | v_1 \in [0, 1]\} & \text{if } u_1 = u_1^*, \\ (0, u_1) & \text{if } u_1 \in (u_1^*, 1], \end{cases}$$

and for a fixed $v_1 \in [0, 1]$, f_2 is maximized at the points of the set

$$M_{f_2}(v_1) = \begin{cases} (v_1, 0) & \text{if } v_1 \in [0, v_1^*), \\ \{(v_1^*, u_1) | u_1 \in [0, 1]\} & \text{if } v_1 = v_1^*, \\ (v_1, 1) & \text{if } v_1 \in (v_1^*, 1]. \end{cases}$$

Intersection of M_{f_1} and M_{f_2} gives the set of the Nash equilibria $N(x, y)$. For $m_1 \geq m_2$ I get

$$N(x, y) = \begin{cases} (v_1^*, u_1^*) & \text{if } x > \frac{m_1 - m_2}{e_1 \lambda_1}, y > \frac{a_1 - a_2}{\lambda_1}, \\ (1, 1) & \text{if } x > \frac{m_1 - m_2}{e_1 \lambda_1}, y < \frac{a_1 - a_2}{\lambda_1}, \\ (1, 0) & \text{if } x < \frac{m_1 - m_2}{e_1 \lambda_1}, \\ \{(1, u_1) | u_1 \in [0, u_1^*]\} & \text{if } x = \frac{m_1 - m_2}{e_1 \lambda_1}, y > \frac{a_1 - a_2}{\lambda_1}, \\ \{(1, u_1) | u_1 \in [0, 1]\} & \text{if } x = \frac{m_1 - m_2}{e_1 \lambda_1}, y \leq \frac{a_1 - a_2}{\lambda_1}, \\ \{(v_1, 1) | v_1 \in [v_1^*, 1]\} & \text{if } x > \frac{m_1 - m_2}{e_1 \lambda_1}, y = \frac{a_1 - a_2}{\lambda_1}. \end{cases}$$

The derivation of the Nash equilibria for $m_1 < m_2$ follows the same lines, and I omit it.

LITERATURE CITED

- Abrahams, M. V. 1986. Patch choice under perceptual constraints: a cause for departures from an ideal free distribution. *Behavioral Ecology and Sociobiology* 19:409–415.
- Bernstein, C., A. Kacelnik, and J. R. Krebs. 1988. Individual decisions and the distribution of predators in a patchy environment. *Journal of Animal Ecology* 57:1007–1026.
- Colombo, R., and V. Křivan. 1993. Selective strategies in food webs. *IMA Journal of Mathematics Applied in Medicine and Biology* 10:281–291.
- Fretwell, D. S., and H. L. Lucas. 1970. On territorial behavior and other factors influencing habitat distribution in birds. *Acta Biotheoretica* 19:16–36.
- Godfray, H. C. J., and S. W. Pacala. 1992. Aggregation and the population dynamics of parasitoids and predators. *American Naturalist* 140:30–40.
- Hassell, M. P., and R. M. May. 1973. Stability in insect host-parasite models. *Journal of Animal Ecology* 42:693–736.
- Hofbauer, J., and K. Sigmund. 1984. *The theory of evolution and dynamical systems*. Cambridge University Press, Cambridge.
- Holt, R. D. 1983. Optimal foraging and the form of the predator isocline. *American Naturalist* 122:521–541.
- . 1984. Spatial heterogeneity, indirect interactions, and the coexistence of prey species. *American Naturalist* 124:377–406.
- . 1985. Population dynamics in two-patch environments: some anomalous consequences of an optimal habitat distribution. *Theoretical Population Biology* 28:181–208.
- . 1987. Prey communities in patchy environments. *Oikos* 50:276–290.
- Kacelnik, A., J. R. Krebs, and C. Bernstein. 1992. The ideal free distribution and predator-prey populations. *Trends in Ecology & Evolution* 7:50–55.
- Lessells, C. M. 1995. Putting resource dynamics into continuous free distribution models. *Animal Behaviour* 49:487–494.
- Murdoch, W. W., and A. Stewart-Oaten. 1989. Aggregation by parasitoids and predators: effects on equilibrium and stability. *American Naturalist* 134:288–310.
- Parker, G. A., and W. J. Sutherland. 1986. Ideal free distribution when individuals differ in competitive ability: phenotype-limited ideal free models. *Animal Behaviour* 34:1222–1242.
- Sibly, R. M. 1991. The life-history approach to physiological ecology. *Functional Ecology* 5:184–191.
- Stephens, D. W., and J. R. Krebs. 1986. *Foraging theory*. Princeton University Press, Princeton, N.J.
- Sutherland, W. J. 1983. Aggregation and the “ideal free” distribution. *Journal of Animal Ecology* 52:821–828.
- Sutherland, W. J., and G. A. Parker. 1985. Distribution of unequal competitors. Pages 255–273 in R. M. Sibly and R. H. Smith, eds. *Behavioural ecology*. Symposium 25 of the British Ecological Society. Blackwell Scientific, Oxford.
- van Baalen, M., and M. W. Sabelis. 1993. Coevolution of patch selection strategies of predator and prey and the consequences for ecological stability. *American Naturalist* 142:646–670.
- Werner, E. E., F. J. Gilliam, D. J. Hall, and G. G. Mittlebach. 1983. An experimental test of the effects of predation risk on habitat use in fish. *Ecology* 64:1540–1548.

Associate Editor: Patsy Haccou